

# Inrichtingsplan

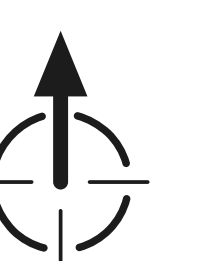

## Principeprofielen



# BEPLANTING



Figuur 1: natuurlijke beplanting met solitaire heesters en bomen



Figuur 2: Vaste planten en grassen, meerstammige bomen



Figuur 3: Siergrassen, meerstammige bomen



Figuur 4: Gemixte vaste beplanting



Figuur 5: Grote plantvakken



Figuur 6: Strakke vakbeplanting met heesters



Figuur 7: Organische plantvakken met bodembedekkers



Figuur 8: Natuurlijke binnenruimte



Figuur 9: Heesterbeplanting met solitaire bomen



Figuur 10: Vaste plantvakken met solitaire heesters



Figuur 11: Schaduwrijke plantvakken met bomen



Figuur 12: Strakke vakken met bodembedekkers en zuilbomen

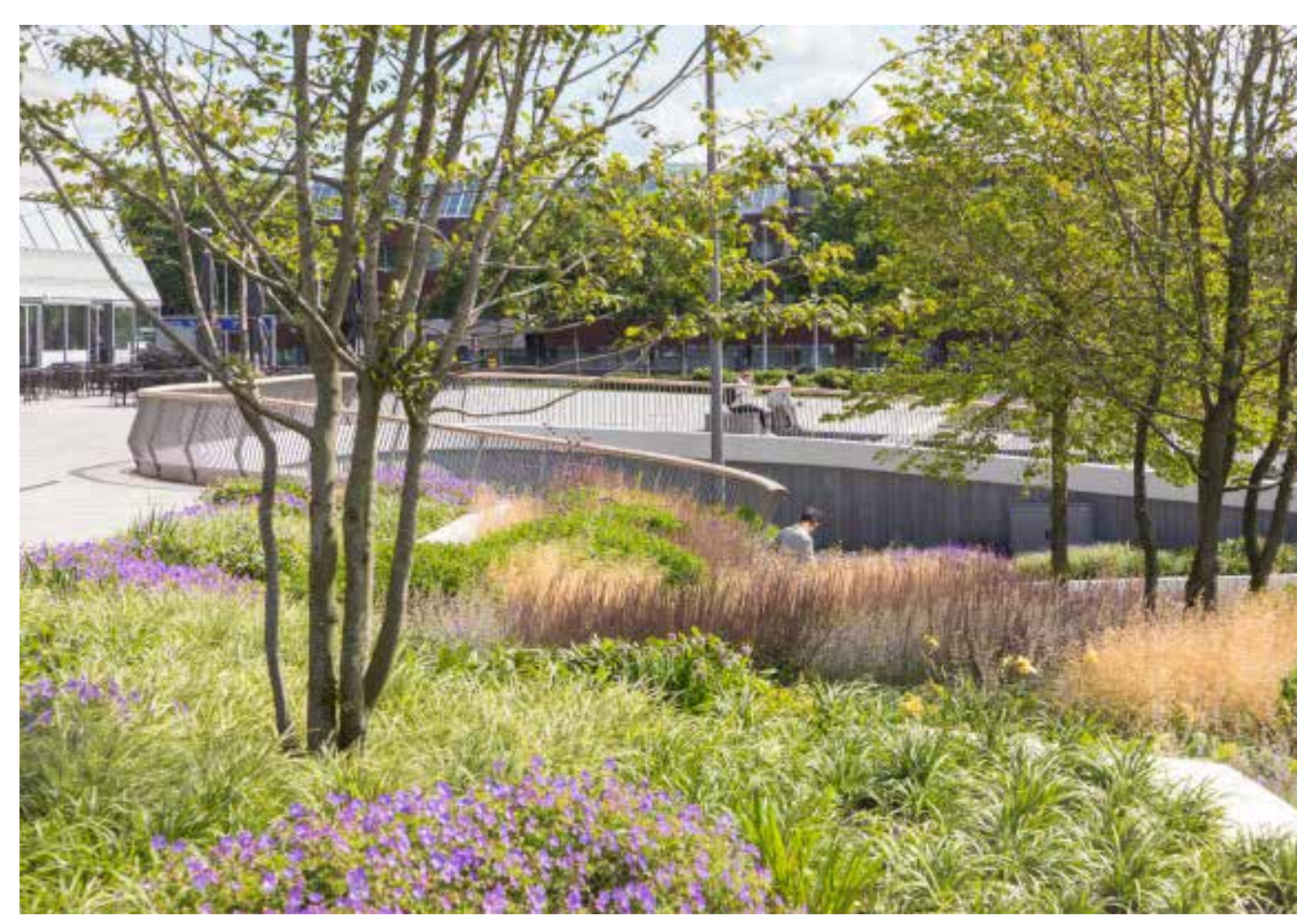

Figuur 13: Siergrassen en vaste planten met meerstammige bomen

# MEUBILAIR

## Speelaanleidingen



Figuur 14: Dukeleek



Figuur 15: Watersturende bestrating als speelaanleiding voor kinderen



Figuur 16: Wipkip in het groen



Figuur 17: Zandbak



Figuur 18: Boomstammen speelaanleiding in de beplanting



Figuur 19: Roken als speelaanleiding in de beplanting

## Verlichting en fietsparkeren



Figuur 20: Fietsniejes in cortenstaal met hout



Figuur 21: Fietsniejes



Figuur 22: Fietsniejes



Figuur 23: Houten staande lichtarmatuur



Figuur 24: Lantaarnverlichting



Figuur 25: Reflecterende markering fietspad



Figuur 26: Houten lantaarn

## Zitgelegenheid



Figuur 27: Betonnen zitrand op plantvak



Figuur 28: Houten bank



Figuur 29: Houten bankjes



Figuur 30: Houten zitting op betonelement



Figuur 31: Houten zitting op plantenbak



Figuur 32: Hout en cortenstaal

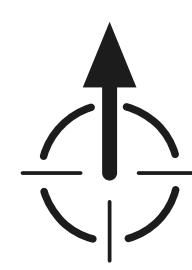

# Afstand tot wonen

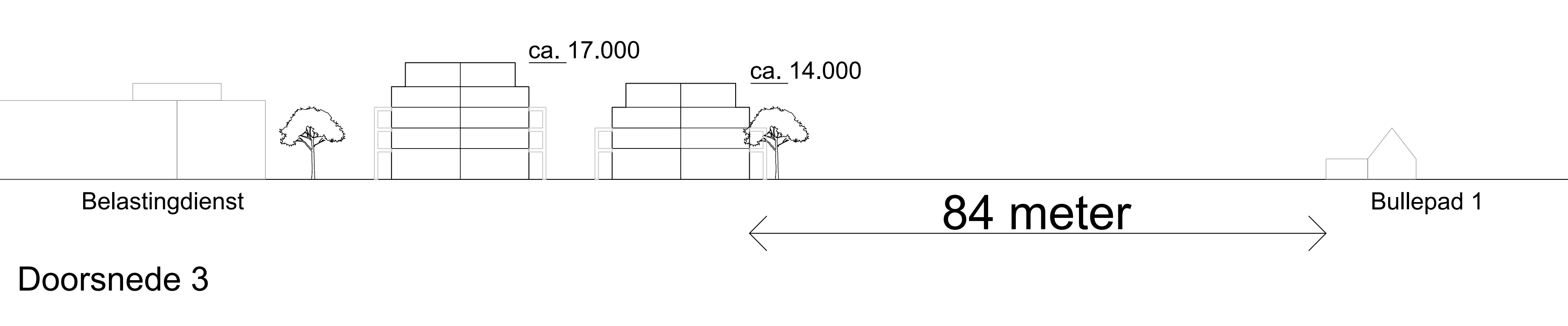
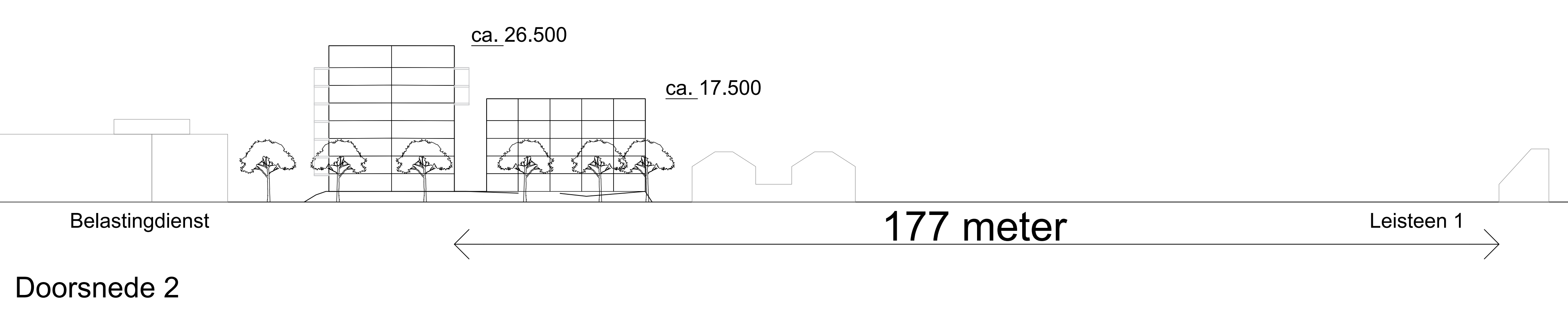
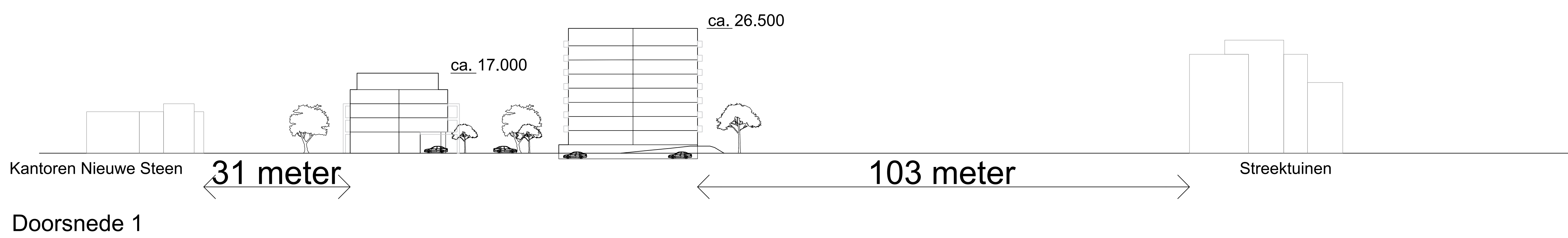

# Impressies

**A**  
**ZEVEN**  
PROJECTONTWIKKELING B.V.



# Impressies

**A**  
**ZEVEN**  
PROJECTONTWIKKELING B.V.



# Impressies



# Impressies

**A**  
**ZEVEN**  
PROJECTONTWIKKELING B.V.



# Planning en proces



	2023		2024				2025 - 2026
	Q3	Q4	Q1	Q2	Q3	Q4	
<b>Planvorming Nieuwe Steen 6</b>							
Ontwerpproces	[Blue arrow from Q3 to Q4]						
Aanvraag omgevingsvergunning		[Blue arrow in Q4]					
Bestuurlijke besluitvorming		[Blue arrow from Q4 2023 to Q3 2024]					
Start verkoop			[Blue arrow from Q1 to Q2 2024]				
Sloop						[Blue arrow in Q4 2024]	
Start bouw						[Orange arrow from Q4 2024 to Q2 2025]	
Oplevering (Medio Q2 2026)							[Orange arrow in Q2 2026]

*Bovenstaande planning is ter indicatie, hieraan kunnen geen rechten worden ontleend.*

Bouwkundig aannemer:



Garantie- & waarborgregeling:

